

FITTING INSTRUCTION

Clamp mark in acc. with		Cables joining
ISO	PN	
1	L	Left directional lights
2	+	Rear fog lights
3	31	Ground
4	R	Right directional lights
5	58R	Right side parking lights
6	54	Stoplights
7	58L	Left side parking lights

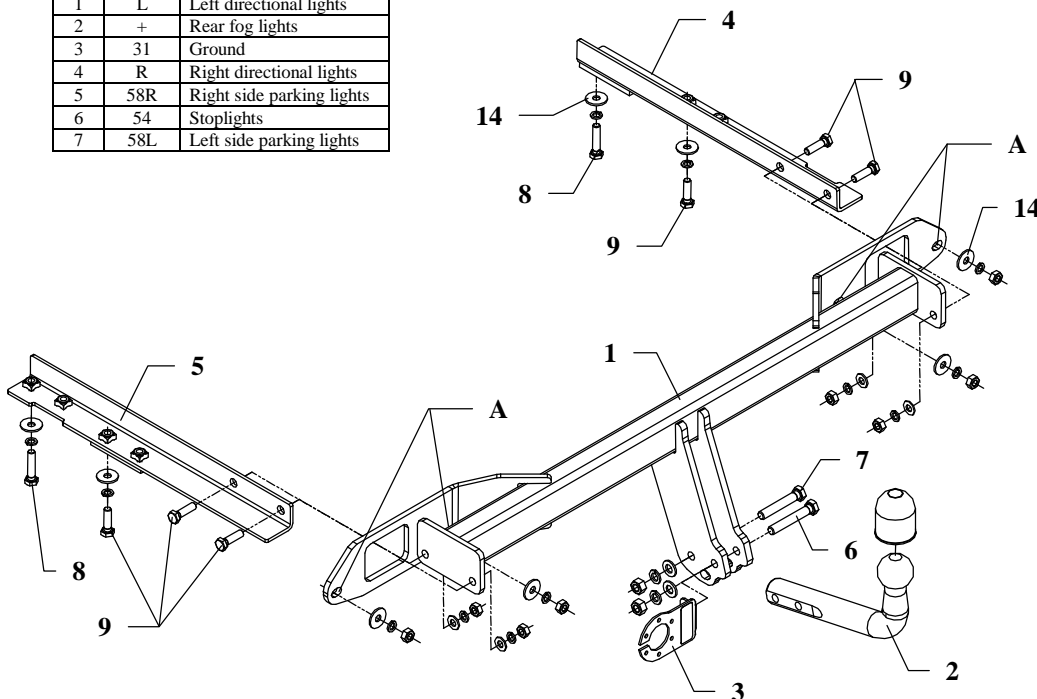

Fig. 1

This towing hitch is designed to assembly in following cars:
OPEL INSIGNIA 4/5 doors and Tourer, produced since 2008, catalogue no. **E52** and is prepared to tow trailers max total weight **2000 kg** and max vertical mass **85 kg**.

From manufacturer

Thank you for buying our product. Their reliability has been confirmed in many tests. Reliability of towing hitch depends also on correct assembly and right operation. For this reasons we kindly ask to read carefully this instruction and apply to hints.

The towing hitch should be install in points described by a car producer.

The instruction of the assembly

1. Disassemble the rear-light units and the bumper with its metal reinforcement. The metal reinforcement will not be assembled again.
2. Apply the main bar of the towing hitch (pos. 1) to rear panel of the vehicle and fix in points A using nuts M10 (see fig. 1).
3. Slip the angle bars (pos. 4 and 5) to chassis members in that way so holes of the angle bars be covered with prepared holes in chassis members (different for 4/5 doors and for Tourer). Fix loosely using bolts M10x45mm and M10x35mm (pos. 8 and 9) – see fig. 1.
4. Fix angle bars to the main bar of the towing hitch (pos. 1) using bolts M10x35mm (pos. 9) – see fig. 1.
5. Install the bumper after cut out of its fragment (see fig. 2).
6. Fix tow ball (pos. 2) using bolt M12x75mm (pos. 6) and M12x70mm (pos. 7). With bolt M12x75mm fix also a socket plate (pos. 3). See figure 1.
7. Tighten all bolts according to the torque shown in the table.
8. Connect electric wires of 7-poles socket according to the instruction of the car.
(Recommend to make at authorized service station).
9. Complete paint layer damaged during installation.

Fig. 2

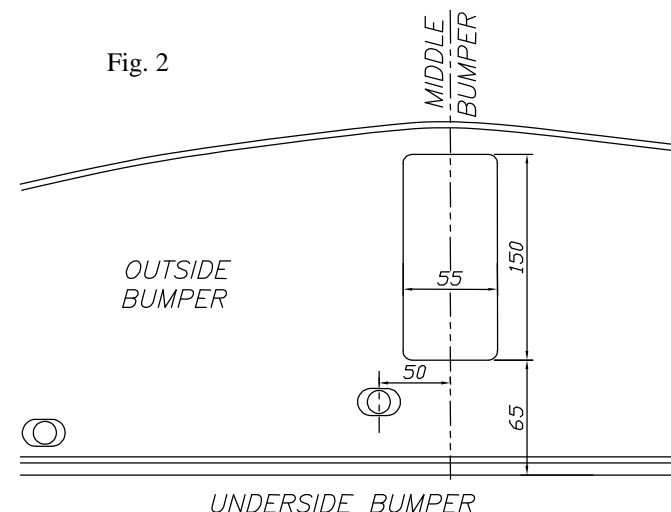

Torque settings for nuts and bolts (8,8):

M6 - 11 Nm	M 8 - 25 Nm	M 10 - 50 Nm
M 12 - 87 Nm	M 14 - 138 Nm	M16 - 210 Nm

NOTE

After install the towing hitch you should get adequate note in registration book (at authorised service station). The car should be equipped with:

- Indicators
- Tow mirrors

After 1000km check all bolts and nuts. The ball of towing hitch must be always kept clear and conserve with a grease.

Towing hitch accessories:

Pos. 1 Main bar PCS.: 1	Pos. 5 Left angle bar PCS.: 1	Pos. 10 Nut 8 B M12 PCS.: 2	Pos. 15 Spring washer ø12mm PCS.: 2
Pos. 2 Tow ball PCS.: 1	Pos. 6 Bolt 8,8 B M12x75mm PCS.: 1	Pos. 11 Nut 8 B M10 PCS.: 8	Pos. 16 Spring washer ø10mm PCS.: 12
Pos. 3 Socket plate PCS.: 1	Pos. 7 Bolt 8,8 B M12x70mm PCS.: 1	Pos. 12 Plain washer ø12mm PCS.: 2	Pos. 17 Ball cover PCS.: 1
Pos. 4 Right angle bar PCS.: 1	Pos. 8 Bolt 8,8 B M10x45mm PCS.: 2	Pos. 13 Plain washer ø10mm PCS.: 4	
	Pos. 9 Bolt 8,8 B M10x35mm PCS.: 6	Pos. 14 Plain washer ø30xø10.5x2.5mm PCS.: 8	



PPUH AUTO-HAK S.J.

Produkcja Zaczepów Kulowych
Henryk & Zbigniew Nejman
76-200 SŁUPSK ul. Słoneczna 16K
tel/fax (059) 8-414-414; 8-414-413
E-mail: office@autohak.com.pl
www.autohak.com.pl

Towing hitch (without electrical set)

Class: **A50-X** Cat. no. **E52**

Designed for:

Manufacturer: **OPEL**

Model: **INSIGNIA**

Type: **4/5 doors, Tourer**

produced since 2008

Technical data:

D-value: 10,6 kN

maximum trailer weight: **2000 kg**

maximum vertical cup mass: **85 kg**

Approval number according to Directive 94/20/EC: **e20*94/20*0744*00**

Foreword

This towing hitch is designed according to rules of safety traffic regulations. The towing hitch is a safety component and can be install only by qualified personnel. Any alteration or conversion of the towing hitch is prohibited and would lead to cancellation of design certification. Remove insulating compound and underseal from vehicle (if present) in the area of the matting surfaces of the towing hitch. The vehicle manufacturer's specifications regarding trailer mass and max. vertical cup mass are decisive for driving whereat values for the towing hitch cannot be exceeded.

D-value formula:

$$\frac{\text{Max trailer weight [kg]} \times \text{Max vehicle weight [kg]}}{\text{Max trailer weight [kg]} + \text{Max vehicle weight [kg]}} \times \frac{9,81}{1000} = D \text{ [kN]}$$